

**Customer Care Solutions  
NPL-2 Series Cellular Phones**

**9 - Car Installation Kit,  
CARK 126**

**Table of Contents**

Description	Page No.
Car Instalation Kit, CARK 126	
Installation Guide .....	3
Introduction .....	3
Warnings .....	4
Components of CARK 126 .....	5
Component Parts .....	6
Mobile Holder MBC-15S .....	6
Swivel Mount HHS-15 .....	6
Mounting Plate MKU-1 .....	6
Handsfree Unit HFU-4 .....	6
System Cable SCU-4 .....	6
Antenna Coupler AXF-15S .....	6
Power Cable PCU-4 .....	6
HF Microphone HFM-8 .....	7
External HF Speaker HFS-12 .....	7
External Antenna .....	7
Privacy Handset HSU-3 (not included) .....	7
Installation .....	7
PCU-4 .....	8
Ignition Sense IGNS .....	8
Car Radio Muting CRM .....	8
Testing .....	9

# Car Installation Kit CARK126

## Installation Guide

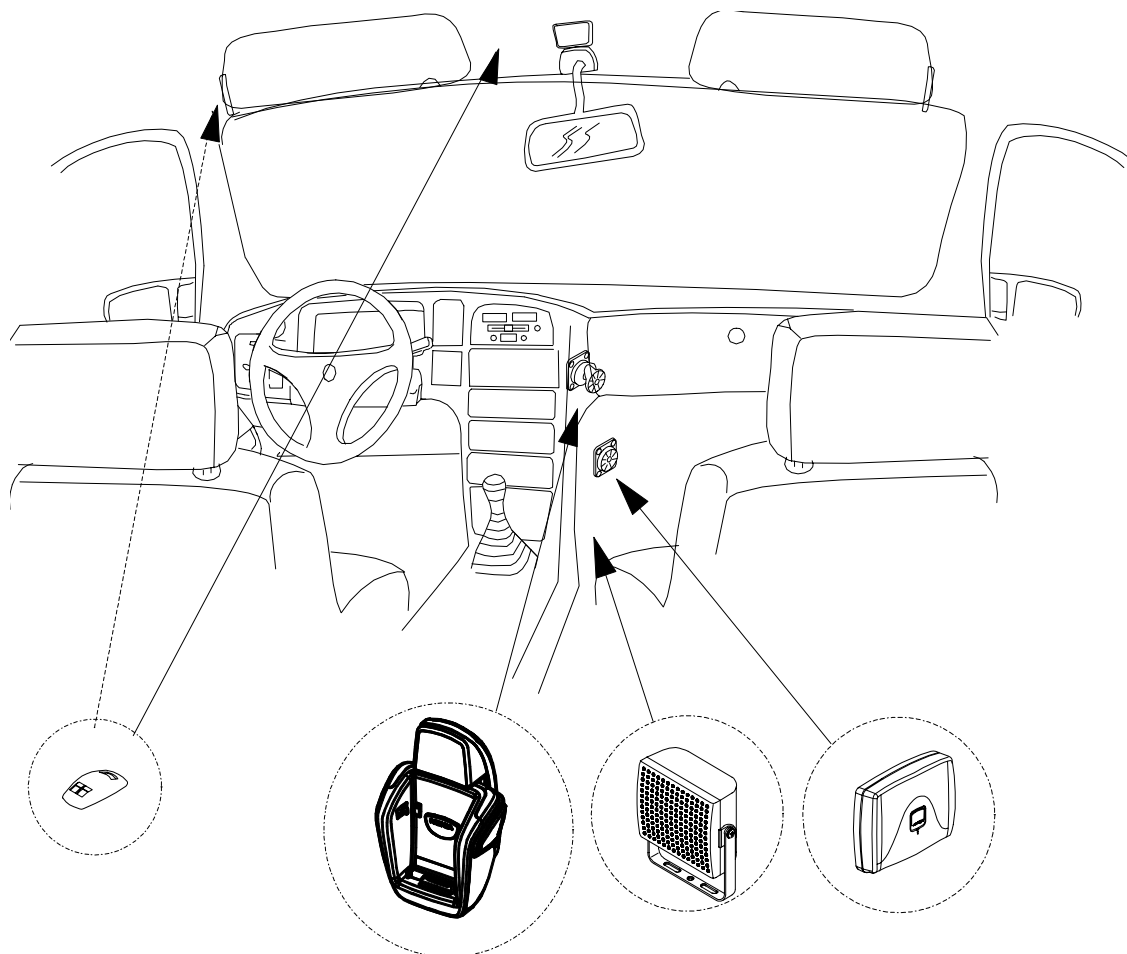

### Introduction

This installation guide has been prepared to provide the basic information necessary to install CARK126. This guide is not intended to be definitive, because different types and models of vehicles will require different installation work. The information given is for general guidance only.

The terms of warranty demand that this car kit be installed by an experienced installer and only genuine Nokia parts are used. An end user should never attempt to install this car kit without professional assistance as the installation requires special tools and knowledge.

Please refer to the telephone's User's Guide for instructions on the telephone's operation, care and maintenance, including important safety information.

Note: Read the warnings below before beginning the installation procedure.

## WARNINGS

- 1 ENSURE THAT THE VEHICLE'S BATTERY IS DISCONNECTED BEFORE YOU START THE INSTALLATION PROCEDURE, AND THAT IT REMAINS DISCONNECTED DURING THE PROCEDURE.
- 2 DO NOT SMOKE OR USE OPEN FLAMES WHEN WORKING NEAR THE VEHICLE'S FUEL SYSTEM.
- 3 ENSURE THAT THE VEHICLE'S ELECTRICAL CABLES, HYDRAULIC LINES, FUEL LINES, AND SAFETY EQUIPMENT ARE NOT DAMAGED DURING INSTALLATION.
- 4 ENSURE THAT NORMAL CONTROL AND OPERATION OF THE VEHICLE IS NOT IMPAIRED BY THE INSTALLATION, PARTICULARLY THE BRAKES AND STEERING. ENSURE THAT AIRBAG OPERATION IS NOT OBSTRUCTED.
- 5 ELECTRONIC AND OTHER SOPHISTICATED SYSTEMS (e.g. SPEED CONTROL, ABS ANTI-LOCK BRAKE, FUEL INJECTION-, NAVIGATION-, AND AIR-BAG SYSTEMS) ARE RELATIVELY IMMUNE TO MALFUNCTION CAUSED BY NEARBY RADIO TRANSMISSIONS. HOWEVER, SHOULD YOU EXPERIENCE FALSE OPERATION OF THESE SYSTEMS OR ARE IN ANY DOUBT WHATSOEVER AS TO THEIR FUNCTIONALITY, PLEASE CONSULT THE VEHICLE'S DEALER.
- 6 THE CAR KIT IS SUITABLE FOR USE ONLY IN VEHICLES WITH A 12 V NEGATIVE GROUNDING. USE ON OTHER SUPPLY VOLTAGES OR ALTERNATIVE POLARITY WILL DAMAGE THE EQUIPMENT.
- 7 THE PHONE SHOULD NOT BE LEFT SWITCHED ON FOR EXTENDED PERIODS WITHOUT RUNNING THE VEHICLE'S ENGINE. FAILURE TO COMPLY COULD DRAIN THE VEHICLE'S BATTERY.

**Components of CARK126**

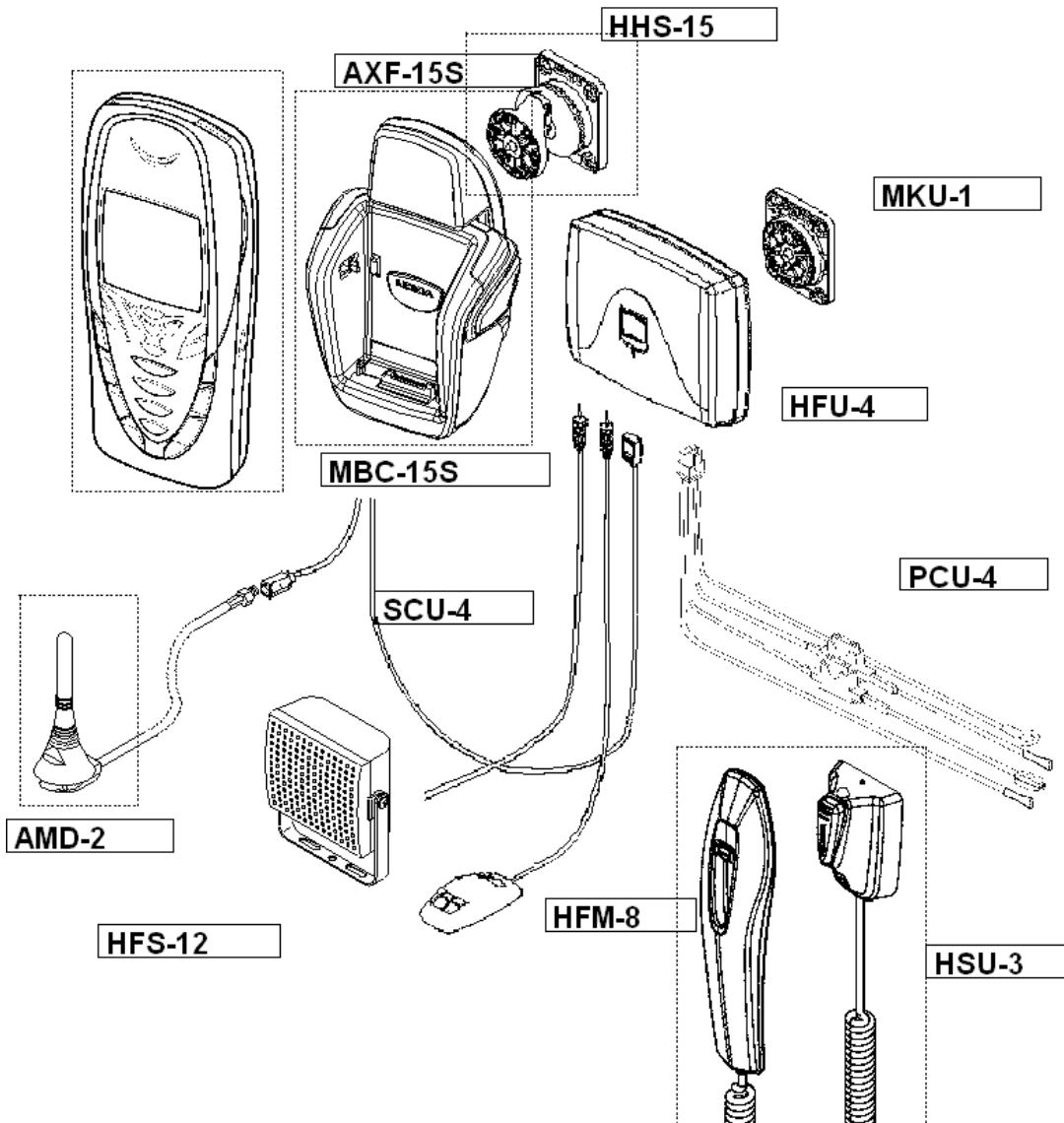

The CARK126 includes the above parts. Please note that the items enclosed in broken-line are not supplied with CARK126 in Europe and Asia.

In the US, Canada and Latin America other sales packages than Cark126 exist. The main difference is that the Mobile Holder and Antenna Coupler are included instead of being sold separately. External antenna AMD-2 is not sold in the US, Canada and Latin America.

Other Mobile Holders connectable to Cark126 are MBC-14M, MBC-13L and MBC-17. MBC-17 is sold in the US, Canada and Latin America both separately as well as a part of Cark 142. Privacy handset HSU-3 is sold in Europe only.

## Component Parts

### Mobile Holder MBC-15S

The holder for the mobile phone is attached to the vehicle's interior always in an upward position, shown in Fig. 2 below, using the swivel mount HHS-15. The mounting is secured with a screw (included with HHS-15). The screw recess is covered with the NOKIA logo plate.

### Swivel Mount HHS-15 and Mounting Plate MKU-1

HHS-15 is a swivel mount which offers two installation methods for the holder MBC-15S. Either use all components to make a swivel mount, or use the flat mounting plate for a fixed position.

For an exploded view, see Figure 2.

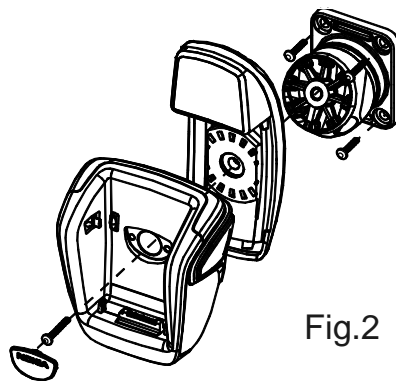

### Mounting plate MKU-1

The handsfree unit HFU-4 is attached to the vehicle interior using the mounting plate MKU-1. The mounting is secured with a screw (included with MKU-1).

### Handsfree Unit HFU-4

The handsfree unit HFU-4 enables the phone to operate in handsfree mode and it is attached to the vehicle interior using the mounting plate MKU-1. The mounting is secured with a screw (included with MKU-1).

### System Cable SCU-4

The system cable SCU-4 plug-in connector connects to the **PHONE** socket in HFU-4 and to the bottom connector underneath the AXF-15S. (The other cable from the AXF-15S connects to the external antenna.) For a diagram, refer to Fig. 1.

### Antenna Coupler AXF-15S

The Antenna Coupler AXF-15S is used to create a contact with an external antenna. It is installed between MBC-15S and secured with a screw (included with AXF-15S). For a diagram, refer to Fig. 2.

### Power Cable PCU-4

The power cable connects to the **DC** socket in HFU-4 and to the vehicle's power supply. See section "Installation" for more information.

### HF Microphone HFM-8

The HF microphone connects to the **MIC** socket in HFU-4. Twist the plug clockwise to lock firmly in place.

### External HF Speaker HFS-12

The HF speaker connects to the **SPEAKER** socket in HFU-4. Twist the plug clockwise to lock firmly in place.

### External Antenna

An external antenna (not included) is recommended for the car kit. It connects to Antenna Coupler AXF-15S. For additional information please refer to documentation supplied with the antenna.

To meet the FCC guidelines for exposure to Radio Frequency device, the external antenna must be installed in a position so that no person will be within 20 cm or 8 inches of the antenna. It is recommended that the external antenna be mounted on the roof of the car in the middle for the center to the back portion of the roof of the car, or, if a convertible, the middle of the trunk lid on that portion closest to the car's interior.

### Privacy Handset HSU-3 (not included)

The Privacy Handset HSU-3 offers more privacy during a call. It connects to the **HAND-SET** socket in HFU-4. For more information, please refer to the user guide for the handset.

## Installation

For an example of installation locations, please see the cover.

The HFU-4 and the different parts are connected as mentioned in the section "Component Parts".

There are some important aspects that require special attention in positioning car kit accessories.

The location of the holder should be selected so that the visibility of phone's display is good and the driver's attention is not distracted. The location of holder should allow the driver to easily reach the keypad. Under no circumstances should the holder prevent the driver from controlling or operating the vehicle in any way.

The HF microphone should be installed according to the directions in the separate microphone installation guide. Ensure the microphone is as close to the driver's mouth as possible, and attached to a surface that is mechanically quiet. The microphone should be mounted at least 3 ft/1 m away from the handsfree unit speaker to avoid acoustic feedback.

Ensure the cables are routed as far away as possible from the vehicle's electronic systems. This is to prevent interference. Also, ensure that cables are not subjected to undue mechanical stress e.g. under seats or against sharp edges.

**Note:** Ensure that the battery of the vehicle is disconnected before you start the installation or making changes to the installations, and that it remains disconnected during the installation procedure.

**PCU-4**

The cables from PCU-4 are colour coded. They are listed in the following table in column A and each cable should be connected to the corresponding item listed in column B.

A	B
Red cable (with 2 amps fuse)	The + voltage on the vehicle's power supply.
Black cable	The negative GND connection.
Blue cable (with 1 amp fuse)	The + 12V voltage controlled by the vehicle's ignition key. (refer to section "Ignition Sense IGNS)
Yellow cable	Used for car radio muting (CRM) and is connected to car radio. The line goes down to 0 volts during a call. Refer to section "Car Radio Muting CRM".

**Ignition Sense IGNS**

The ignition sense feature prevents your car kit from draining the car battery by executing an auto power off in 20 seconds after the ignition key has been turned off. The blue cable from PCU-4 is used for the ignition sense feature. The use of ignition sense is recommended to prevent accidental draining of the car battery. The cable is connected via a 1 A fuse to a 12 volt supply that is controlled by the ignition key. Do not connect it directly to the high voltage sections of the ignition circuit.

**Car Radio Muting CRM**

The car kit offers a feature that can mute the car radio automatically during a phone conversation. The following is the circuit diagram of CRM.

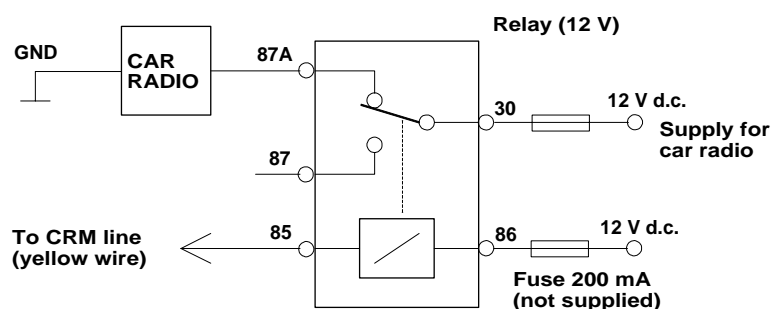

Another possibility is to use a special muting unit, which mutes the radio by connecting load resistors to the speaker lines of the car radio.

A third possibility for the customer is to refer to the car radio user manual to determine whether there is a CRM cable or point of connection in the car radio available. Then the CRM line from CarK126 can be directly connected to either of those.



All installations should take into account any special requirements of the customer. However, should the customer require an installation that is illegal or unsafe these facts must be pointed out to the customer and a policy of non-compliance adopted.

**Testing**

Once installed, the equipment should be tested to ensure that it is operating satisfactorily and that the position of the units does not impair the driver's ability to control and operate the vehicle in any way.

**This page has been intentionally left blank**